



SERVICE PARTS LIST

BULLETIN NO.
54-40-1160

SPECIFY CATALOG NO. AND SERIAL NO. WHEN ORDERING PARTS		REVISED BULLETIN	DATE
8-1/4" CIRCULAR SAW CATALOG NO. 6405-6 SERIAL NUMBER 552C		54-40-1159	July 2001
		WIRING INSTRUCTION 58-01-0754	

FIG.	PART NO.	DESCRIPTION OF PART	NO. REQ.
1	02-04-0850	Ball Bearing	(1)
2	02-04-2650	Ball Bearing	(2)
3	02-04-2775	Ball Bearing	(1)
4	02-50-2423	Needle Bearing	(1)
7	06-65-1535	1/8 x 3/4" Roll Pin	(1)
★ 8	06-75-0030	5/16-18 x 9/16" Blade Screw	(1)
9	06-82-7299	8-16 x 7/8" Slit. Pan Hd. Plastite T-20 Screw	(4)
10	06-82-5317	8-32 x 1/2" Slit. Pan Hd. Tapt. T-20 Screw	(2)
11	06-82-7253	8-32 x 3/8" Slit. Pan Hd. Tapt. T-20 Screw	(1)
12	06-82-7270	8-16 x 5/8" Slit. Pan Hd. Plast. T-20 Screw	(4)
13	06-82-7453	8-16 x 2-1/4" Slit. Pan Hd. Plast. T-20	(4)
14	42-96-0130	Bearing Cup	(1)
15	06-95-0335	1/4-20 x 1/2" Fil. Hd. Screw	(2)
16	06-82-7395	8-16 x 1-3/4" Pan Hd. Plastite T-20 Screw	(2)
17	06-95-3250	8-32 x 5/8" Fil Hd. #2 Phil. Tapt. Screw	(4)
★ 18	12-20-1190	Service Nameplate Kit	(1)
★ 19	16-70-0310	120 V Armature	(1)
20	22-84-0655	Fan Assembly	(1)

EXAMPLE:

00	0
----	---

 Component Parts (Small #) Are Included When Ordering The Assembly (Large #).

★ = Part number change from previous service parts list.

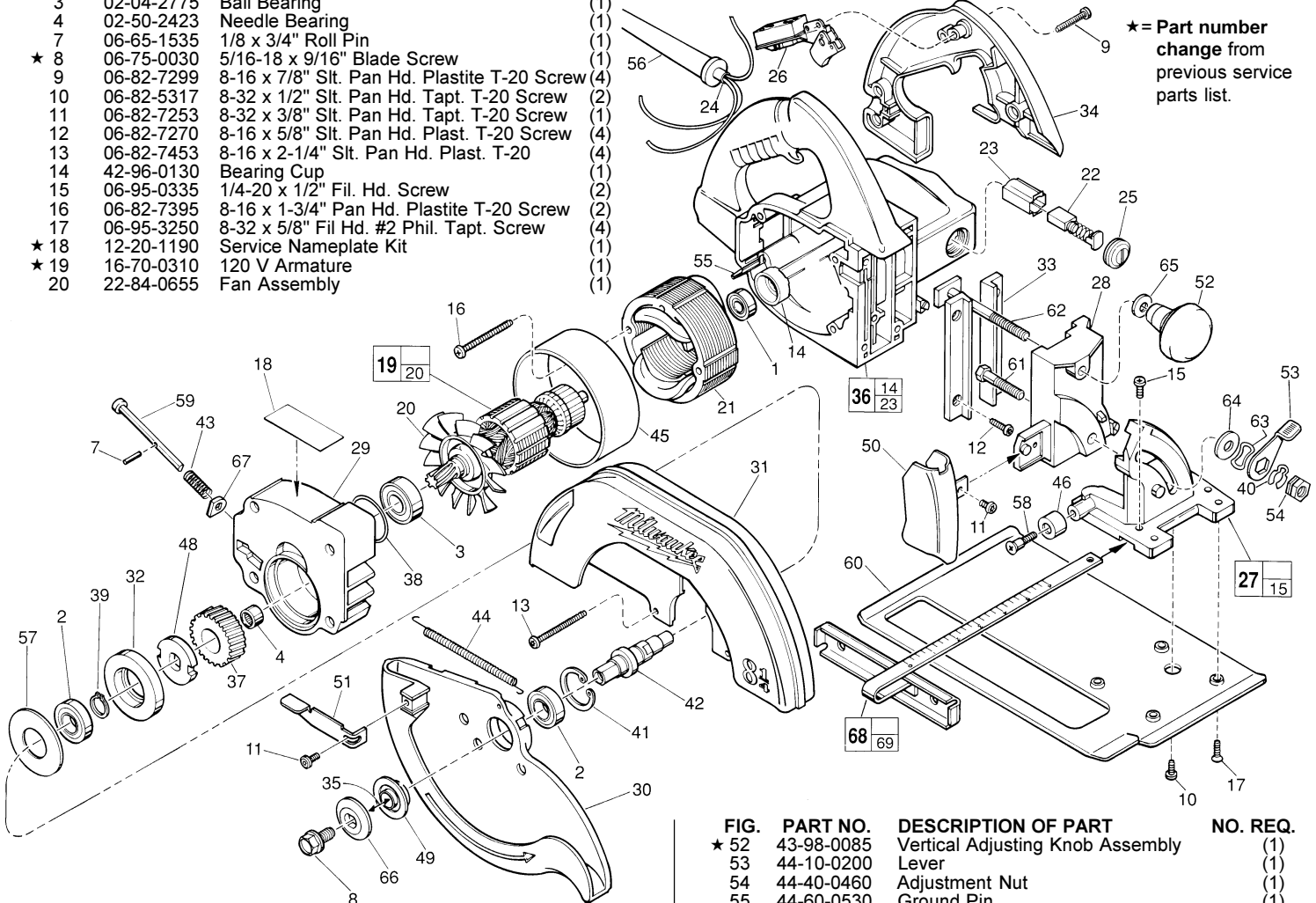

FIG.	PART NO.	DESCRIPTION OF PART	NO. REQ.
★ 21	18-70-0045	120 V Field	(1)
22	22-18-0550	Carbon Brush Assembly	(2)
23	22-20-0820	Brush Insert	(2)
★ 24	22-64-0015	Cord Set	(1)
25	23-44-0160	Brush Retaining Screw	(2)
★ 26	23-66-2110	Switch	(1)
27	28-10-0791	Angular Adjusting Bracket	(1)
28	25-10-0810	Vertical Adjusting Bracket	(1)
29	28-14-2170	Gear Case	(1)
30	28-41-0930	Lower Guard	(1)
31	25-41-0939	Upper Guard	(1)
32	28-53-0280	Hub	(1)
33	28-72-0049	Vertical Adjusting Plate	(2)
34	31-44-1422	Left Handle Half	(1)
35	-----	8-1/4" Blade (Select from Catalog)	(1)
36	31-50-1041	Motor Housing Assembly	(1)
★ 37	32-75-3205	Gear	(1)
38	34-40-1375	1-1/4" O-Ring	(1)
39	34-60-1200	Retaining Ring	(1)
40	34-60-2330	Klipring	(1)
41	34-80-2600	Internal Retaining Ring	(1)
★ 42	38-50-5826	Spindle	(1)
43	40-50-8040	Spindle Lock Spring	(1)
44	40-50-8350	Lower Guard Spring	(1)
45	42-14-0310	Baffle	(1)
46	42-38-0223	Bumper	(1)
48	42-74-0090	Spindle Locking Cog	(1)
49	43-34-0710	Inner Flange	(1)
50	43-54-0547	Front Blade Guard	(1)
51	43-62-0910	Lower Blade Handle	(1)

FIG.	PART NO.	DESCRIPTION OF PART	NO. REQ.
★ 52	43-98-0085	Vertical Adjusting Knob Assembly	(1)
53	44-10-0200	Lever	(1)
54	44-40-0460	Adjustment Nut	(1)
55	44-60-0530	Ground Pin	(1)
56	44-76-0050	Cord Protector	(1)
57	44-86-0520	Bearing Retainer Plate	(1)
58	45-04-0505	Bumper Screw	(1)
59	45-08-0200	Spindle Lock Shaft	(1)
60	45-16-0575	Shoe	(1)
61	45-58-0270	Angular Adjusting Stud	(1)
★ 62	45-58-0310	Vertical Adjusting Stud	(1)
63	45-88-0577	Wave Washer	(1)
64	45-88-8460	Angular Adjusting Washer	(1)
★ 65	45-88-0690	Adjusting Washer	(1)
66	45-88-8200	Spindle Washer	(1)
67	45-88-8250	Felt Washer	(1)
68	49-22-4150	Rip Fence (Optional)	(1)
69	06-87-2450	1/4-20 x 1/2" Thumb Screw (Not Shown)	(2)
	49-96-6205	9/16" Box Wrench (Not Shown)	(1)

FIG. 10,11 **NOTE**
 44 Apply Blue Loctite, Type CV-242.
 Hooks of spring must be completely inserted in slots. Long hook in upper guard.
 48 Radius on locking cog must be up against face of gear.
 59 Flat of spindle lock shaft must face gear.

FIG. 27,28,33 **LUBRICATION**
 Apply a light coat of teflon dry spray lubricant to all sliding surfaces.
 29 1/2 Oz. Type "Y" Grease, No. 49-08-5270.

MILWAUKEE ELECTRIC TOOL CORPORATION
 13135 W. LISBON RD., BROOKFIELD, WI 53005
 Dwg. 3