

WIRING INSTRUCTIONS

TITLE

CIRCULAR SAW

**BULLETIN
58-01-1251**

MILWAUKEE ELECTRIC TOOL CORP. 13135 WEST LISBON RD. BROOKFIELD, WIS.

DATE
Oct. '92

NOTE: Wires to be inserted in switch so that insulation is subflush to opening.

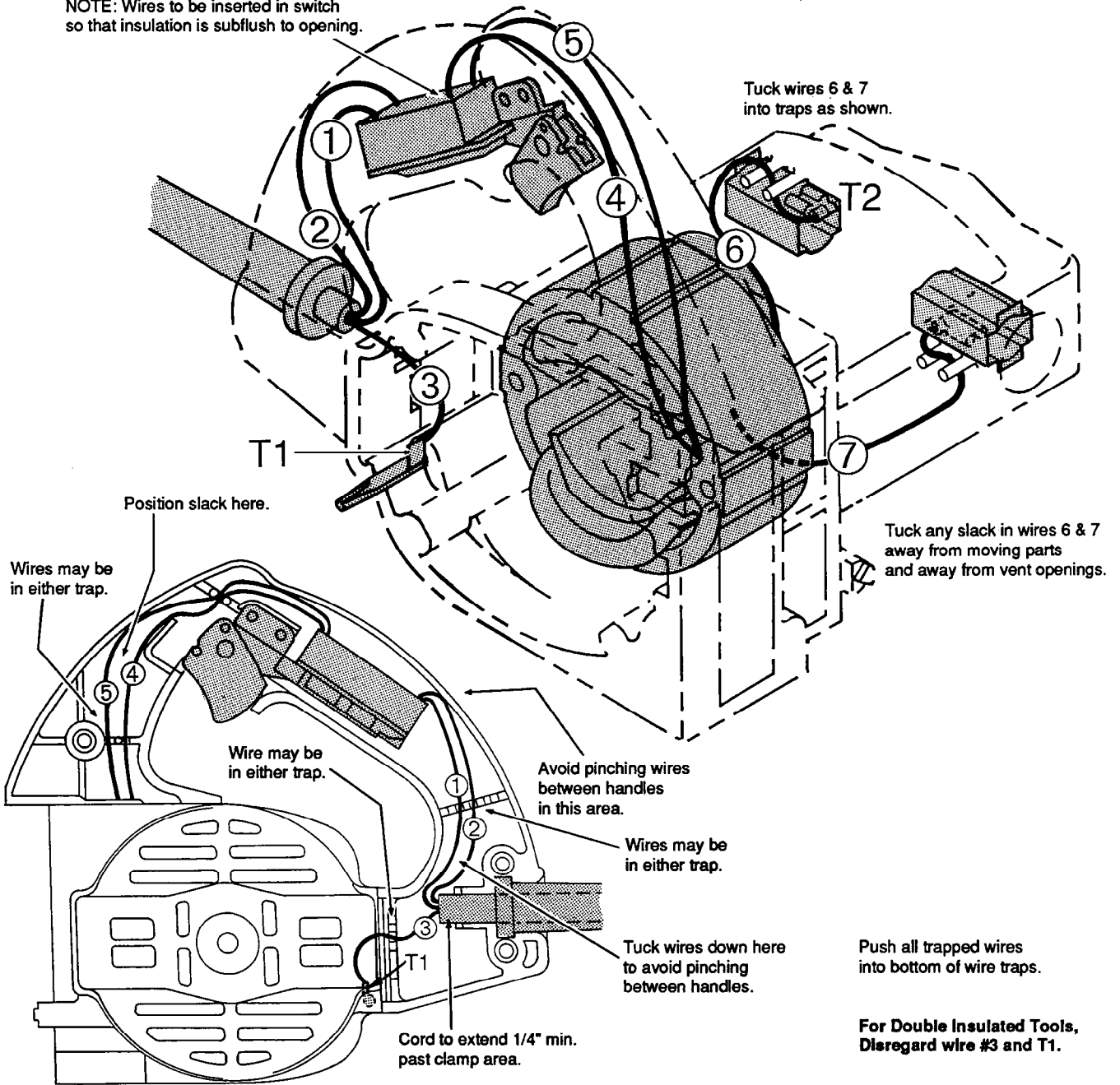

Push all trapped wires into bottom of wire traps.

**For Double Insulated Tools,
Disregard wire #3 and T1.**

WIRING SPECIFICATIONS

Wire No.	Wire Color	Origin or Part No.	Gauge	Length	Terminals, Connectors and End Wire Preparation
1	White	Cord	16	5"	Strip 3/8" and tin.
2	Black	Cord	16	5"	Strip 3/8" and tin.
3	Green	Cord	16	2-1/4"	Strip 3/16" for T1.
4	Yellow	Field	16	8-7/8"	Strip 3/8" and tin.
5	Black	Field	16	8-7/8"	Strip 3/8" and tin.
6	Yellow	Field	16	3-1/2"	Strip 3/16" for T2.
7	Black	Field	16	3-1/2"	Strip 3/16" for T2.

NOTE:
All leads must be held to $\pm 1/8"$.
All lead lengths are before stripping.

TERMINAL DESCRIPTION		
Code	Part No.	Qty.
T1	23-74-0615	1
T2	23-74-0300	2